

# **Pyrotechnic Articles used to activated Devices In Motor Vehicles**

The Point of View of the Automotive Suppliers Industry

Presented on behalf of CLEPA  
by  
Klaus Pilatus  
Autoliv





## **Facts about CLEPA**

- . 3000 Member companies in total, representing 2500 SMEs**
- . 3 Million employees**
- . 300 Billion Euro sales**



# Pyrotechnic Articles in a Vehicle

Various airbags for front impact protection

Various airbags for side impact protection

Activators for different purposes:  
•Hoodlifter  
•Battery cutter

Seat Belt pretensioners

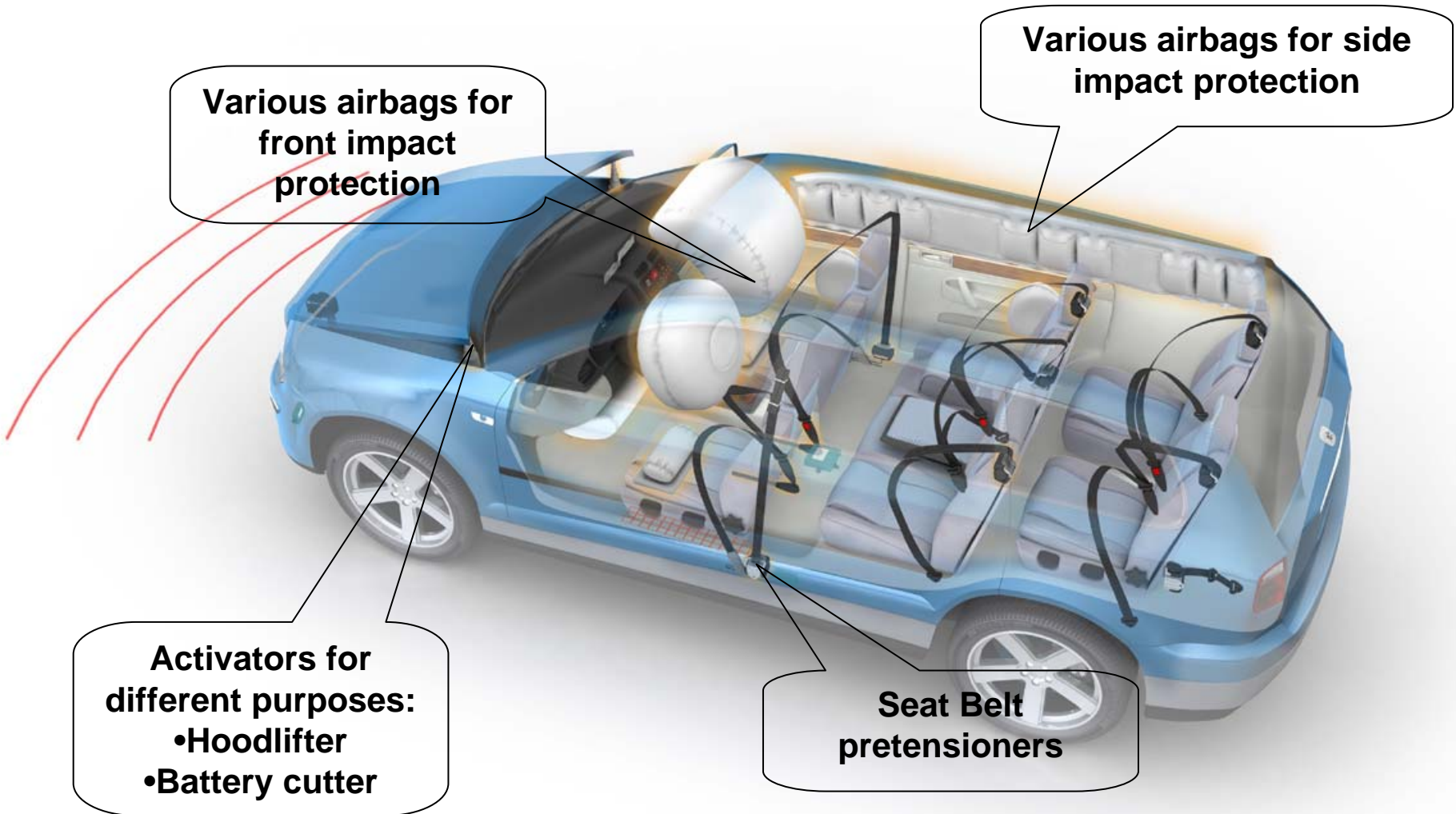

# Dimension of Market

- **Airbag systems placed on the market up to now:**
  - Appr. 80 Million
- **Seatbelt units with pyrotechnic place on the market up to now:**
  - Appr. 90 Million
- **Total value:**
  - Appr. €5 Billion
- **Number of employees in the related suppliers industry in Europe:**
  - Appr. 30 Thousand



## Airbag Module in a Steering Wheel



**Cover**

**Cushion**

**Gas Generator/  
Inflator**



# Gas Generator/Inflator

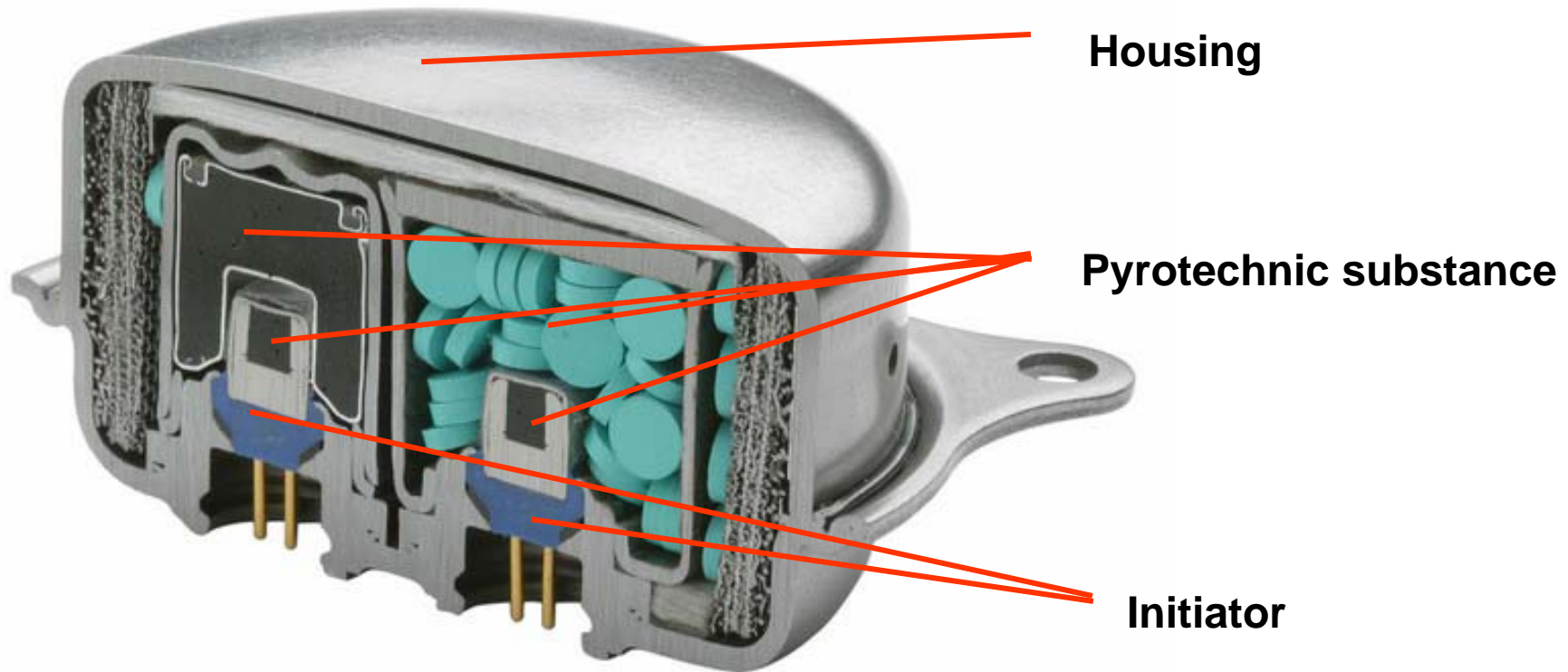



# Passenger Airbag Module and related Gas Generators/Inflators



**Pyrotechnic substance**

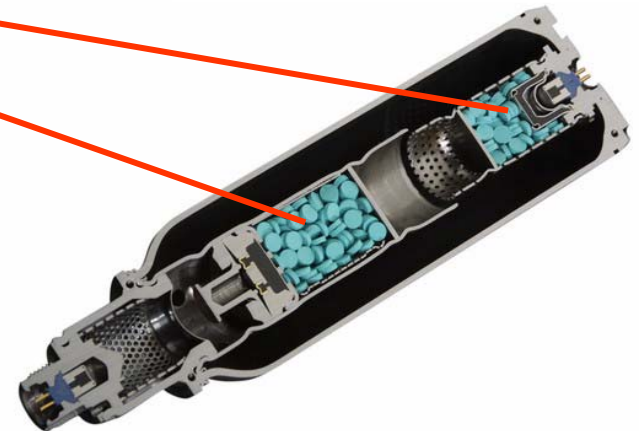
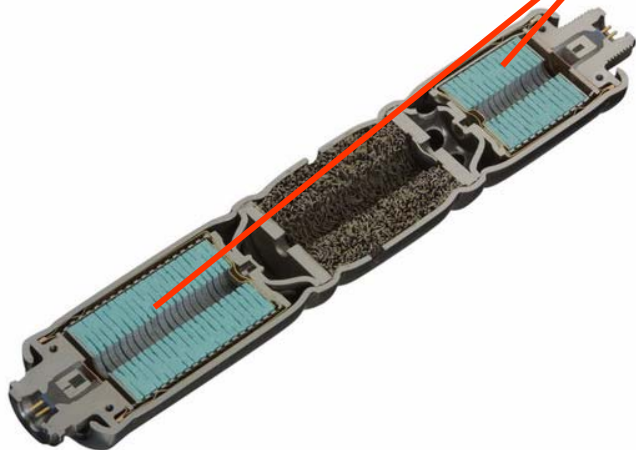

# Head Protection System for Lateral Impact



**Hybrid Inflator**





# Hybrid Gas Generators/Inflators

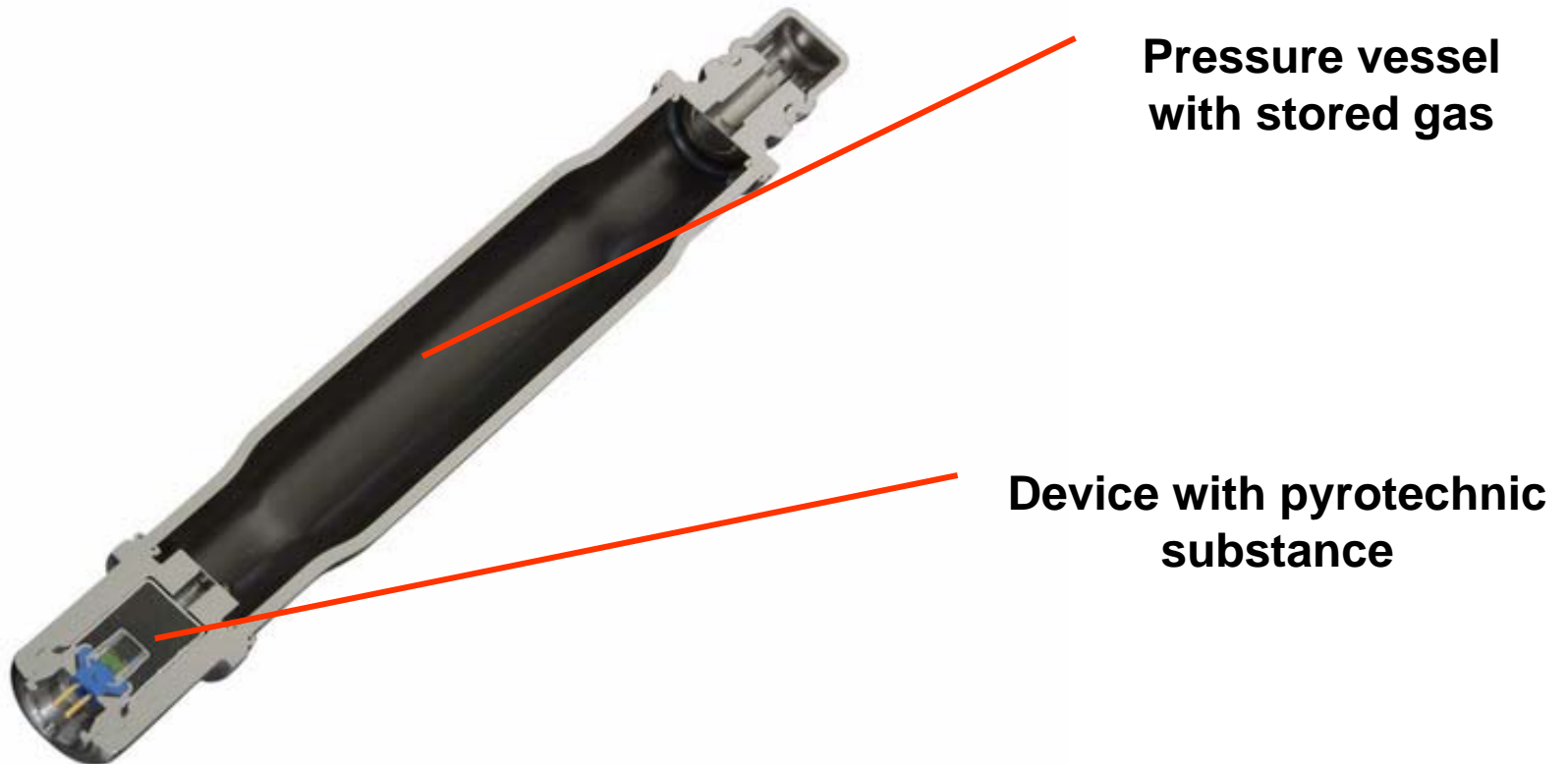

# Buckle Pretensioner



**Micro  
Gasgenerator**

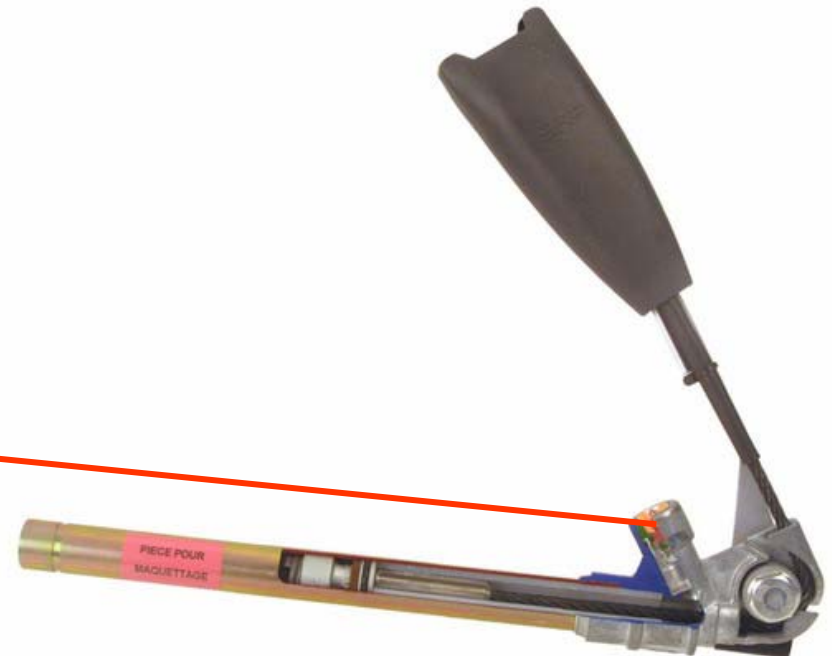



**CLEPA**  
*European Association of  
Automotive Suppliers*

# Leadwire Gas Generator & Buckle Pretensioner





# Retractor Pretensioner

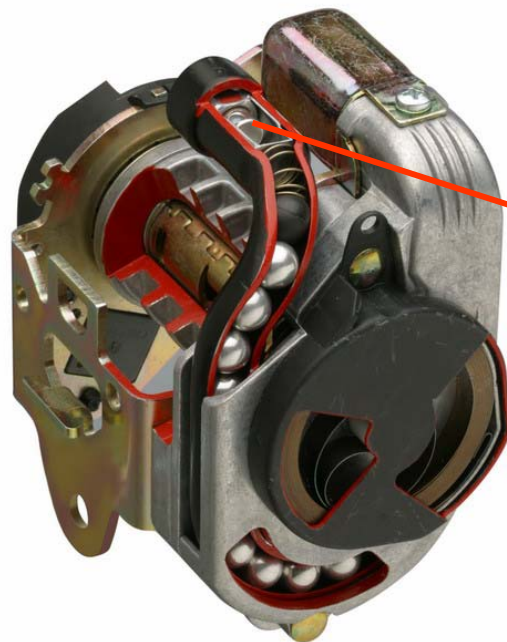

**Micro  
Gasgenerator**





# Pyrotechnic Safety Switch

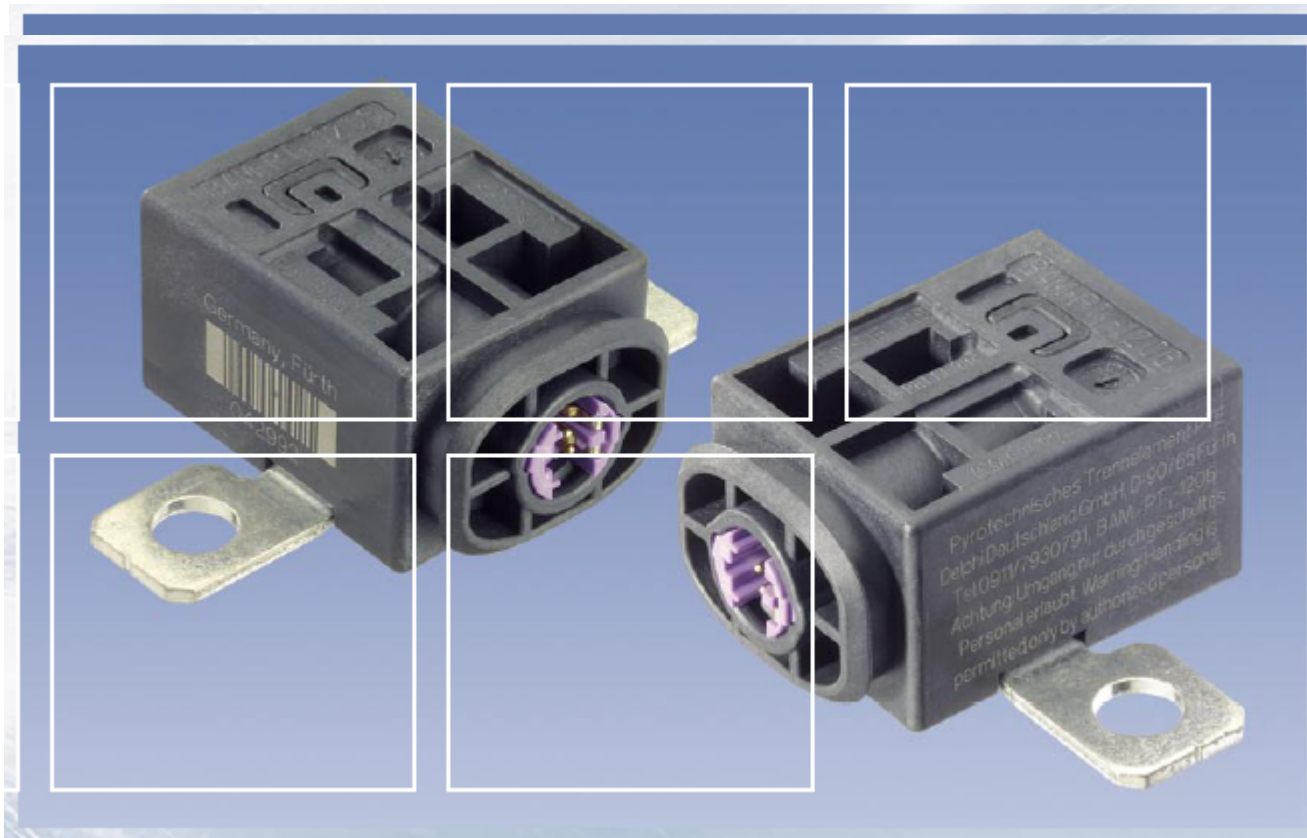



# Pyromechanic Actuator

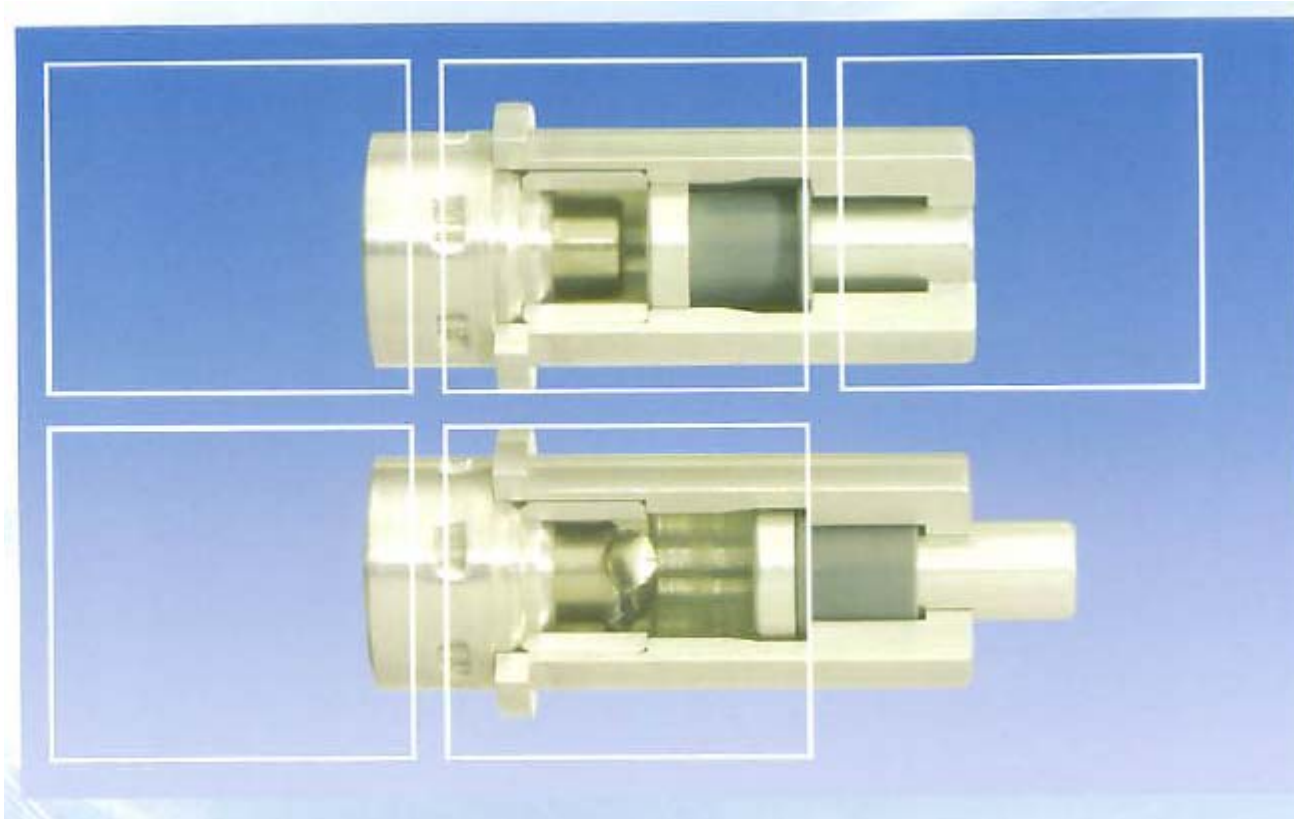



# Micro Gas Generator

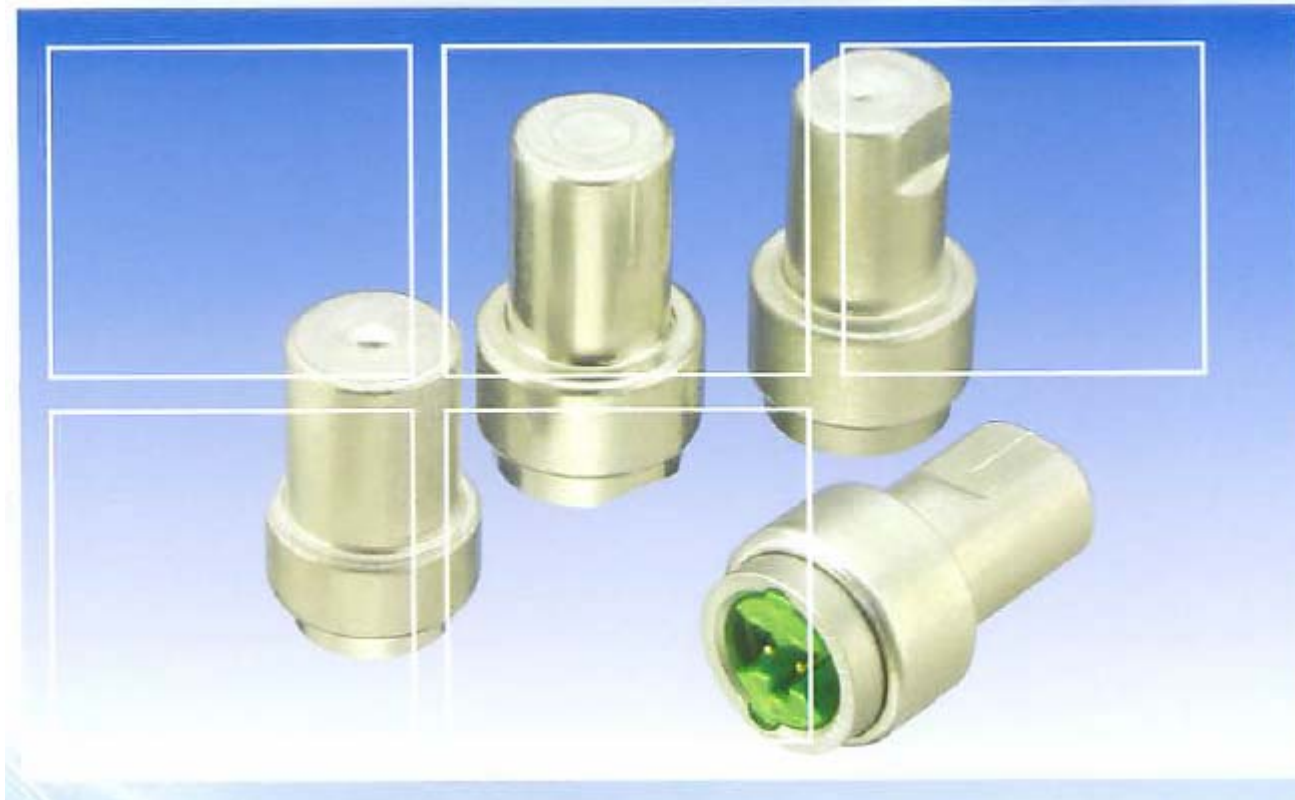



# Production Facility for Gas Generators

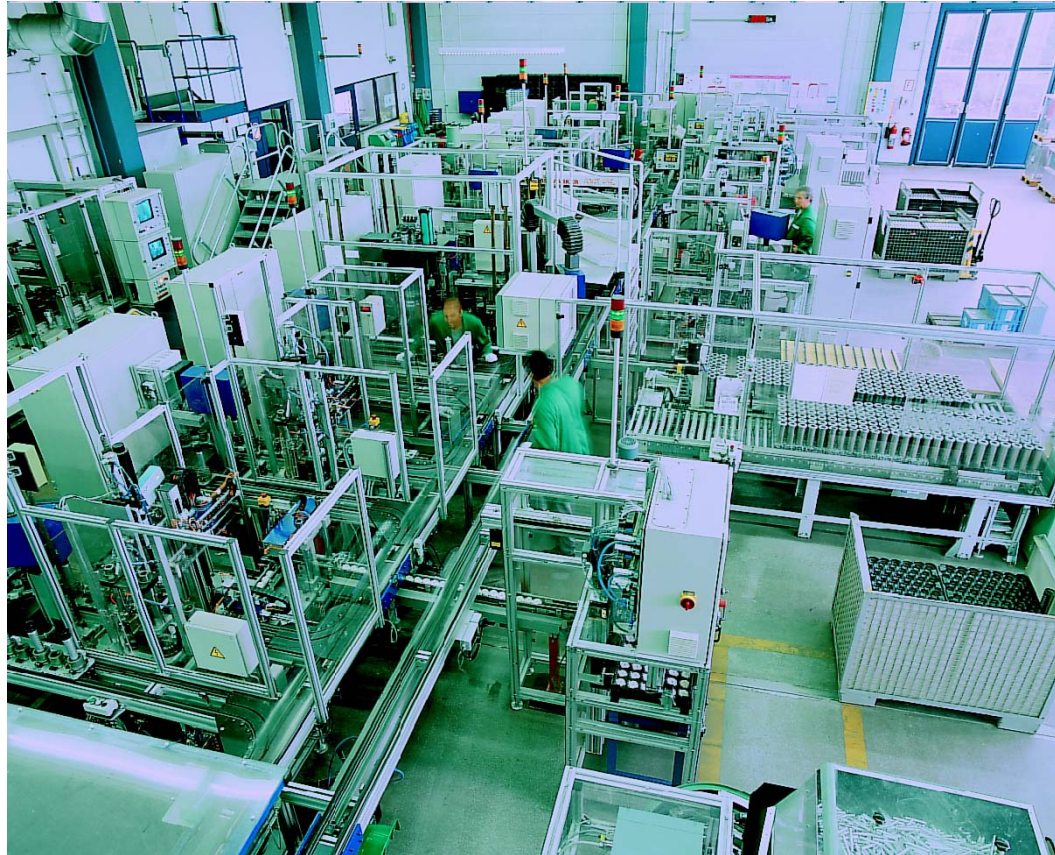

- Entire area protected for Electrostatic Discharge (ESD) by grounded floor and personal equipment (shoes, clothing)
- Grounded assembly units



**CLEPA**  
European Association of  
Automotive Suppliers

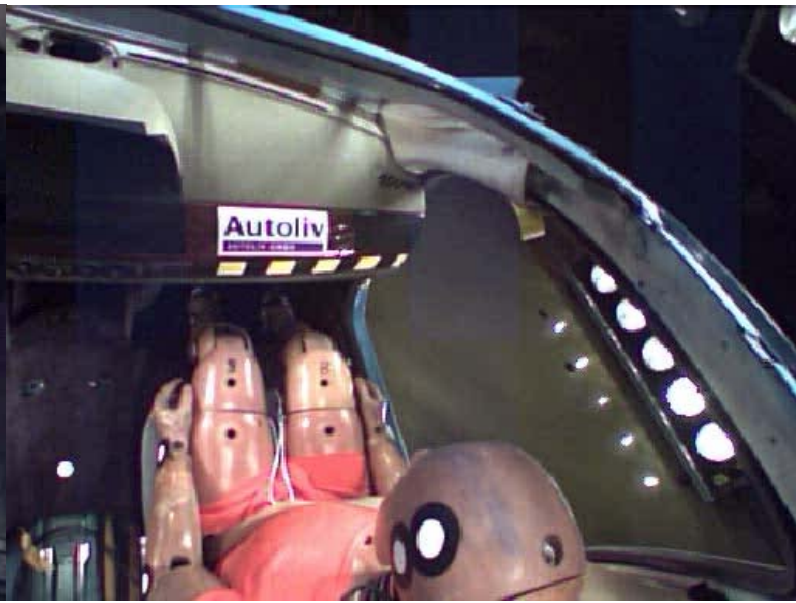
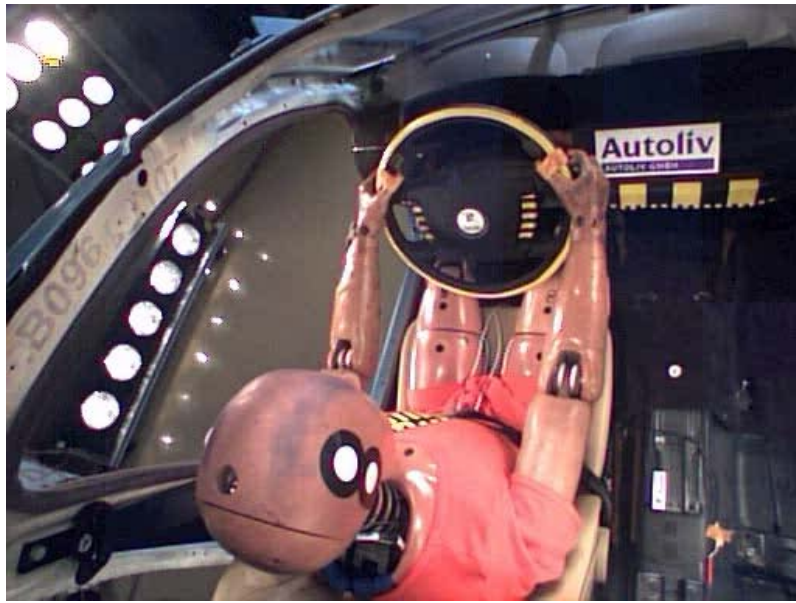

## **CLEPA Position on the draft Directive**

- **CLEPA** fully supports the objectives of the draft Directive and would like to have it adopted as soon as possible.
- But **CLEPA** has some concerns with the Commission's draft, due to the nature of our activities: sales to professional users in an industrial context.

## **CLEPA Concerns**

- Certification only once (definition of article and of Placing on the Market to be made more clear)
- Safeguard clauses: any actions by Member States or Commission must be duly justified, with time limits.
- Labelling requirements (kind/amount of information on a label, languages)